

Gas Analysis System for Metabolic Analysis of Physiology (GASMAP) Qualify

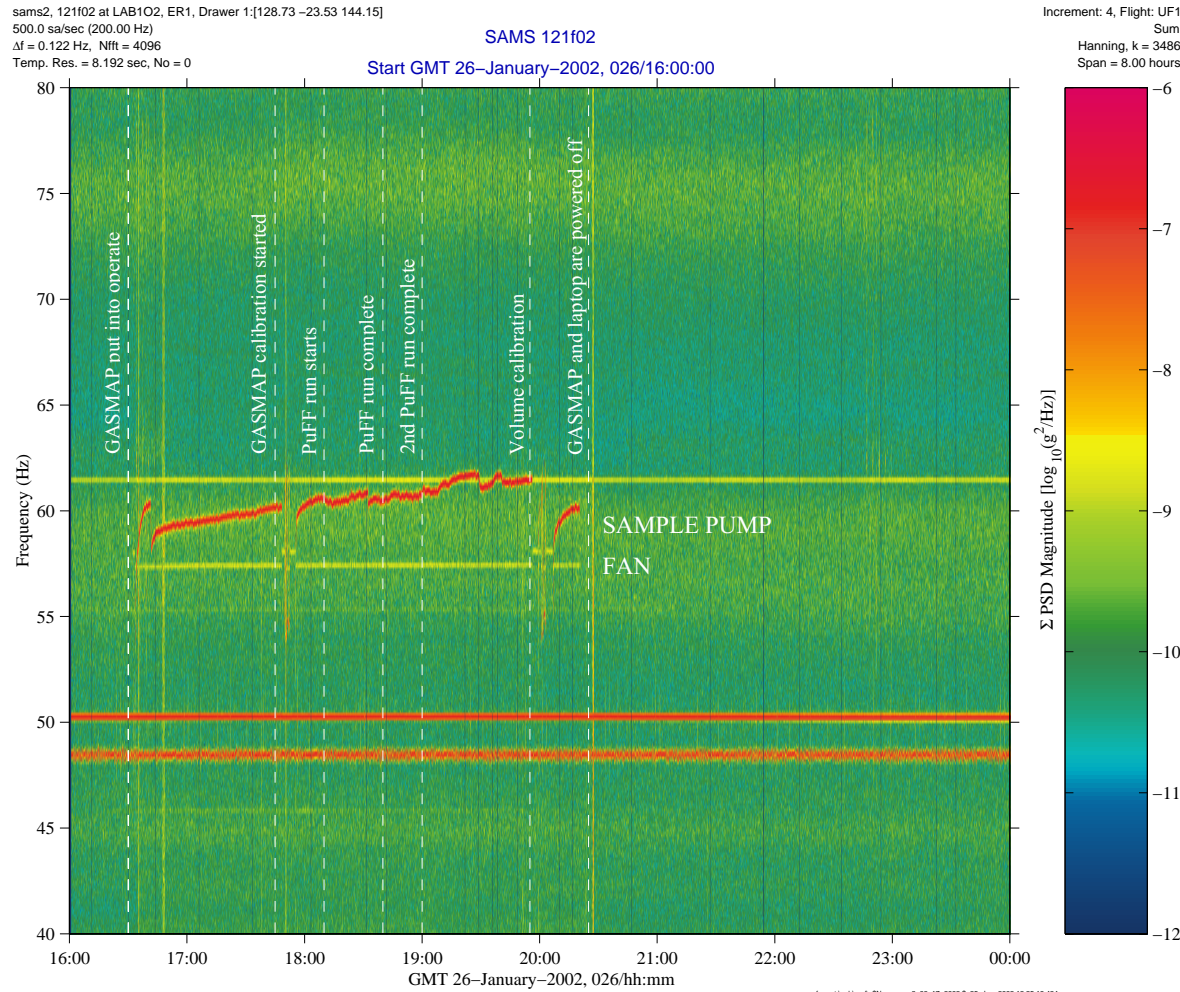

Data Description	
Sensor	121f02 500.0 sa/sec (200.00 Hz)
Location	LAB1O2, ER1, Drawer 1
Inc/Flight	Increment: 4, Flight: UF1
Plot Type	spectrogram

Notes:

The GASMAP device is used to monitor and analyze both inhaled and exhaled breath streams to determine their gas concentrations. Two GASMAP signatures are noted in the figure near 60 Hz: **a sample pump and a fan**. This equipment is located in the HRF rack #1 (LAB1S2) and used for the Pulmonary Function in Flight (PuFF) experiment, which studies effects of extravehicular activity (EVA) and long-term exposure to microgravity on the pulmonary function. As discussed with payload developers, the frequency changes away from nominal operation are likely a function of varying loads on the sample pump. The pump frequency ranged from 54 Hz (for brief calibrations) up to 62 Hz after the second PuFF run. The fan is tightly controlled in frequency but also transitions from baseline of about 57.4 Hz up to 58.1 Hz noted during calibrations.



Microgravity Science Division



Glenn Research Center

Regime:	Vibratory
Category:	Experiment Equipment
Source:	GASMAP

Gas Analysis System for Metabolic Analysis of Physiology (GASMAP) Quantify

Data Description	
Sensor	121f02 500.0 sa/sec (200.00 Hz)
Location	LAB1O2, ER1, Drawer 1
Inc/Flight	Increment: 4, Flight: UF1
Plot Type	interval RMS

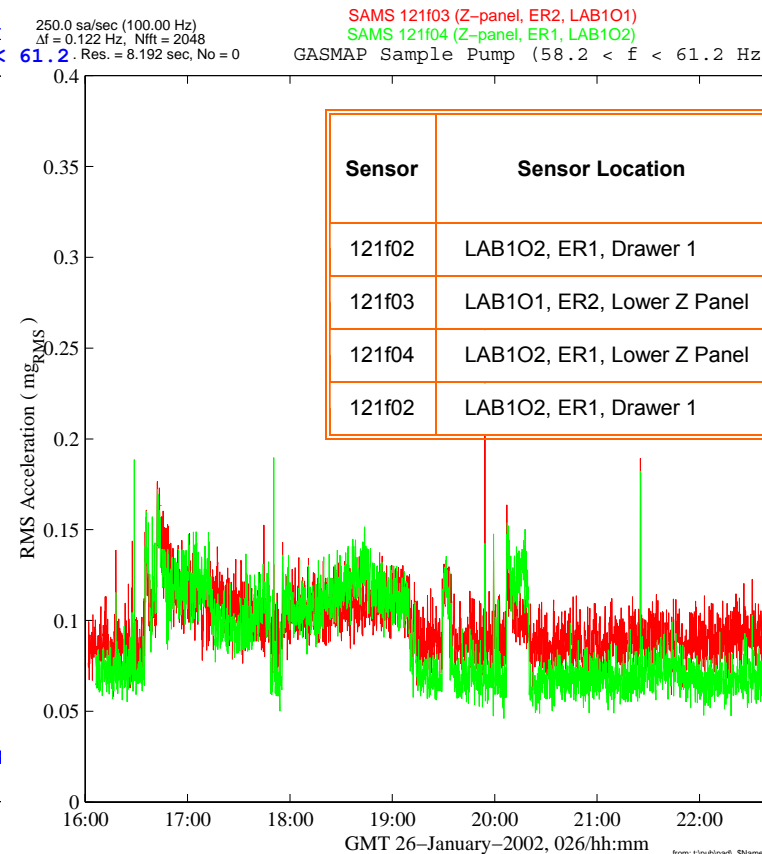
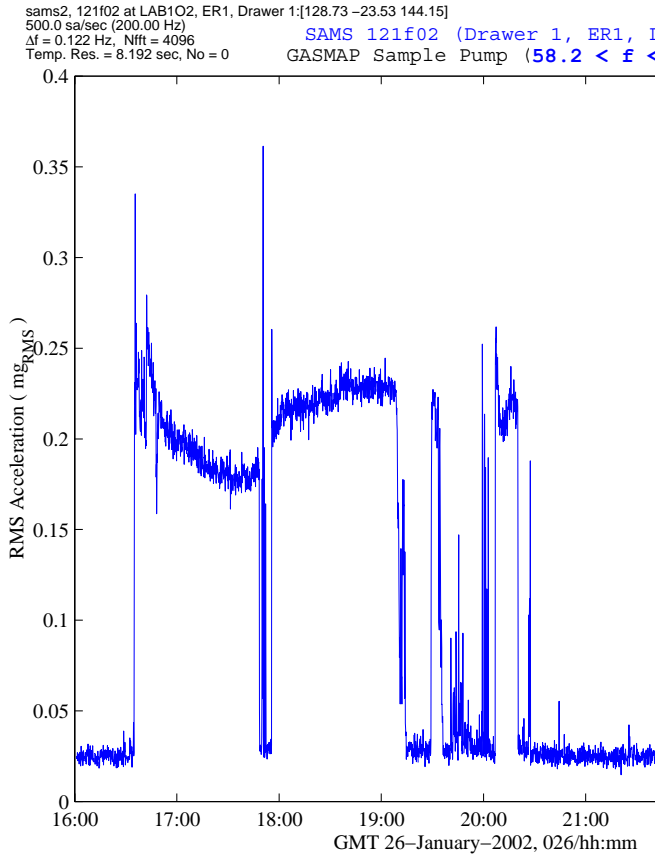

Sensor	Sensor Location	GASMAP Equipment	Frequency Range (Hz)	State	RMS Acceleration (ug _{RMS})
121f02	LAB1O2, ER1, Drawer 1	SAMPLE PUMP	58.2 - 61.2	OFF	24
				ON	>200
OFF	91				
ON	>115				
121f04	LAB1O2, ER1, Lower Z Panel	FAN	57.2 - 57.6	OFF	70
ON	>115				
121f02	LAB1O2, ER1, Drawer 1	FAN	57.2 - 57.6	OFF	8
				ON	19

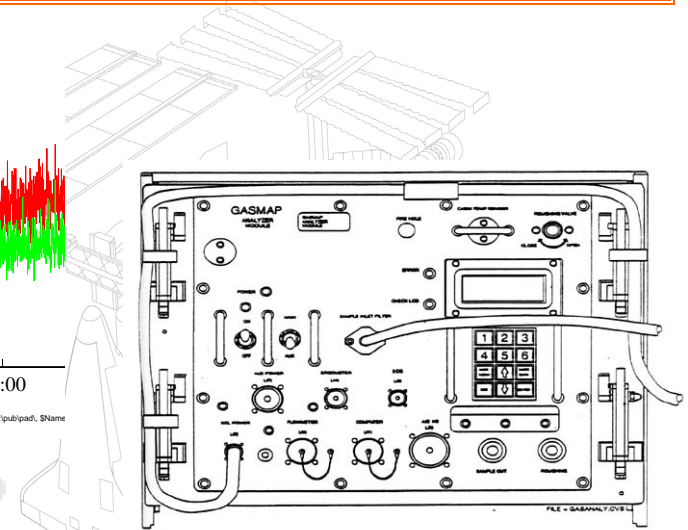

Microgravity Science Division

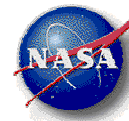

Glenn Research Center

PIMS ISS Acceleration Handbook
Date last modified 10/2/02

Regime:	Vibratory
Category:	Experiment Equipment
Source:	GASMAP